

PREPARING – AND PREPARING TO DELIVER – TREATMENT PLANT MASTERPLANS

Julianne Martin (Lutra), Caroline Crosby (Lutra), Jonathan Church (Lutra), Asli Crawford (Horowhenua District Council)

ABSTRACT (500 WORDS MAXIMUM)

Horowhenua District Council is anticipating significant population and industrial growth in Levin over the next 30-years, as well as being faced with upgrading aging and deteriorating assets at both their water and wastewater plants. Challenges relating to climate change, environmental stresses and changing regulations need to be addressed. Lutra were engaged to develop 30-year masterplans for both the water and wastewater treatment plants to meet these needs. The masterplans were required to deliver a robust programme of work, beginning with upgrades and initiatives to meet immediate operational needs that followed on logically to the needed longer-term upgrades.

The first part of this paper sets out in detail the method used to prepare the master plans including defining immediate and longer term needs and aspirational goals; assessing the operational state of the current plant and then gathering supporting evidence to revise and refine the plan and timelines for delivery. In carrying out the master planning process it becomes clear that technical expertise and infrastructure planning expertise need to be applied equally for the best outcomes. To develop a feasible and evidence-based upgrade path, it is not sufficient to produce 'high level concept designs'.

The second part of the paper sets out the challenges for Horowhenua District Council in delivering the masterplans. Infrastructure managers face a number of challenges including bringing on stakeholders early and often throughout the project, managing budgets and needing to spend more than allocated in the long-term plan, obtaining additional funds, and gathering the right internal and external team with respect to capability and competence to deliver the Masterplan projects.

The Levin experience creates a case study of the issues and problems facing three waters infrastructure providers in New Zealand.

KEYWORDS

Masterplanning, infrastructure planning, technical expertise, water treatment, wastewater treatment

PRESENTER PROFILE

A chartered professional engineer, Julianne has worked with Lutra for a number of years on a range of water and wastewater projects from inception, through to optioneering, design and delivery including commissioning.

Asli Crawford is a chartered engineer with 12 years' experience in the Petrochemical and O&G industries around the world and in New Zealand. Asli has worked in the three-waters space for the past six years.

1. INTRODUCTION

Horowhenua District Council (HDC) is anticipating significant population and industrial growth in Levin over the next 30-years, as well as being faced with upgrading aging and deteriorating assets mainly at the Levin wastewater plant. Challenges relating to climate change, environmental stresses and changing regulations need to be addressed. Lutra were engaged to develop 30-year masterplans for both the water and wastewater treatment plants to meet these needs while future-proofing the plants for beyond this timeframe. The masterplans were required to deliver a robust programme of work, beginning with upgrades and initiatives to meet immediate operational needs that followed on logically to the needed longer-term upgrades.

2. BACKGROUND

2.1 EXISTING WASTEWATER TREATMENT INFRASTRUCTURE

The Levin Wastewater Treatment Plant (WWTP) started construction in its current form in around 1967. Further modifications were made in 1971 (operations building), 1990 (solids contact process) and 1996 (second primary clarifier, anaerobic digester and sludge tank). A new effluent pumping station has also been constructed within the last 10-years.



Figure 1: Levin WWTP, Aerial

The treatment now consists of pre-treatment screening / grit removal, primary clarification, a trickling-filter/solids-contact process for secondary treatment,

secondary clarification, and stabilisation ponds before being pumped to an effluent irrigation site at the "Pot" (land-based forest disposal). Ponds are also used for wet weather flow balancing. Solids treatment consists of a picket fence thickener, anaerobic digestion and dewatering by rotary belt press. Solids are taken off-site for disposal and biogas is used for heating the digesters only.

A schematic for the WWTP is shown in Figure 1.

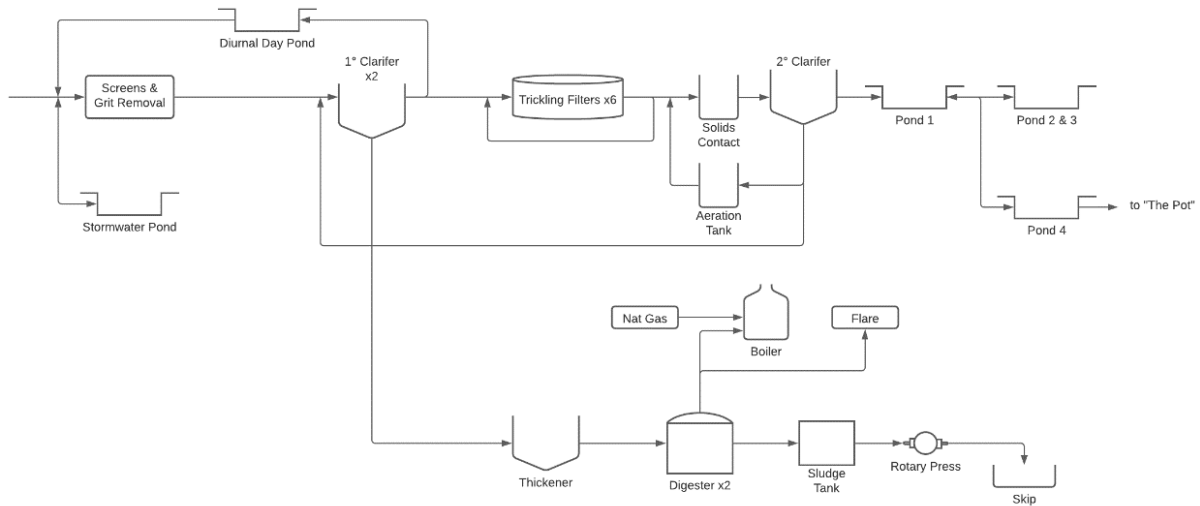

Figure 2: Levin WWTP, Existing Process

The older anaerobic digester has been removed from service twice in the past 2- years to repair structural leaks and to refurbish the mixing gas blower. The remedial work was expected to provide an additional 2-5 years of life. Remedial work is also planned for the newer digester.

2.2 EXISTING WATER TREATMENT INFRASTRUCTURE

The Levin WTP was constructed in its current location in 1964 and consisted of a sedimentation pond for the river water source and 6 horizontal pressure filters. Four more filters were added in 1968 and an infiltration gallery was added in 1995. A sedimentation channel, "the snake", was built in 2002 to provide additional settlement time for the raw water. A major upgrade (\$6.4 million) occurred in 2017 which included the addition of clarification (actiflo), UV treatment that could also be used for control of taste and odour compounds in the source, a new treated water storage reservoir and an upgrade to the waste system. The media filters were not upgraded in 2017 and are the original structures installed in the 1960's. The media has however been replaced regularly.



Figure 3: Levin WTP, Aerial

The treatment now consists of a surface water intake via infiltration gallery, raw water pumping to the plant, clarification by actiflo including applicable chemical dosing, media filtration, UV disinfection, post treatment chlorine dosing and storage. As noted before, the UV unit can also be used for taste and odour control although this has not been required so far. Waste treatment utilizes the old settlement ponds and dewatering is provided by a geobag with filtrate returned to the Ōhau River.

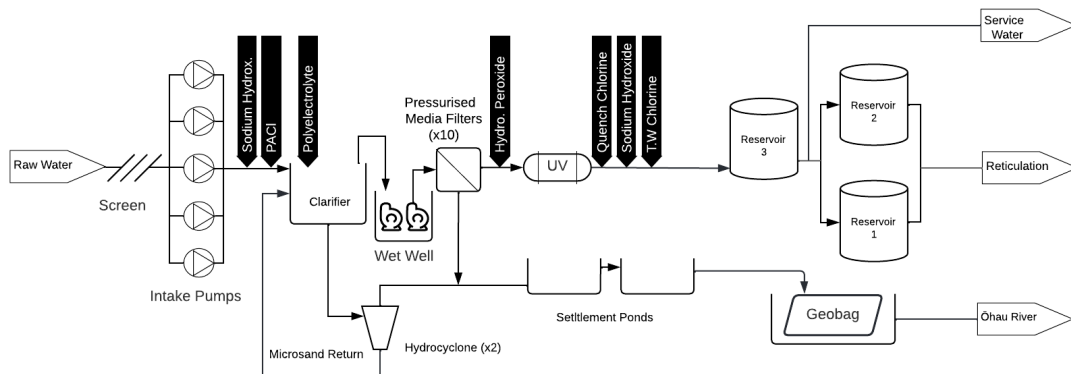

Figure 4: Levin WTP, Existing Process

2.3 EXPECTED GROWTH

The current population of Levin is estimated to be 22,000 and this is expected to grow to 58,000 by 2050, an increase of 163%. Growth is expected for several reasons:

- The completion of transport infrastructure projects such as transmission gully, Peka Peka to Ōtaki expressway, Ōtaki to North Levin, and the Manawatū Tararua Highway
- High numbers of migrants to New Zealand.
- The lifestyle (between the beautiful Tararua Ranges and the coast) and favourable micro-climate on offer to residents.
- The strategic location of the Horowhenua district along SH1.

Commercial and industrial consumption and discharges are also expected to grow over this period which will serve and stimulate the population growth. Estimates for this growth are not well defined (as is common for industrial predictions) therefore assumptions were developed for the masterplan process.

A sensitivity analysis was carried out using high and low estimates of population and commercial and industrial discharges however it is acknowledged that this is only ever an estimate and will always be “wrong” in the long term. The job of the master plan is therefore to develop a pathway forward that will account for the lack of certainty in this estimate.

2.4 NEW LEGISLATIVE REQUIREMENTS

HDC has obligations relating to the operation of both the WTP and WWTP under (but not limited to) the Local Government Act 2002, Health and Safety at Work Act 2015, the Resource Management Act 1991, the National Policy Statement on Freshwater Management 2020 (NPS-FM), and now the Water Services Act 2021 (WSA).

New obligations under the water services act include:

- Section 14: Giving effect to Te Mana o te Wai. This means that water suppliers must consider the impact of their water (and wastewater) operations on the wellbeing of the source water but also the management of activities in the catchment that affect the water source. Critical to the decision making regarding a water supply and its source is involvement with iwi as their values and objectives are part of Te Mana o te wai. This is also required in the NPS-FM. It forms an intrinsic part of Taumata Arowai’s modus operandi.
- Section 139: Preparation of a wastewater network risk management plan which identifies hazards and assesses the risks associated with the wastewater system. The risk management plan must also identify the ways in which the risks can be managed, controlled, monitored or eliminated. The definition of wastewater network includes treatment plants and their discharges.
- Section 138: Taumata Arowai (after consultation) also has the ability to set wastewater environmental performance standards that could apply to the discharges or by-products produced by a plant, the way in which energy is used and waste introduced by a third party.
- Section 29: HDC Officers now have an obligation to act with due diligence to comply with legislative requirements, however, elected members of the governing body of a local authority do not. In the present state this means

council officers have limited control over budgets and therefore identifying and escalating risk for consideration may be the best they can do to meet this requirement.

2.5 ENVIRONMENTAL CHALLENGES

Emerging natural hazards such as climate change effects are already being seen in the Horowhenua region with Horizons Regional Council research showing that there has been an increase in temperatures, changes to rainfall patterns, increased drought and ongoing sea level rise. As such HDC are working on the expectation that this will continue and intensify in the future.

This has impacts when considering future water sources and the health and wellbeing of water bodies impacted by drinking water and wastewater infrastructure.

It also has implications for drinking water and wastewater infrastructure. Water may be harder to treat because of wet weather events and consequent floods and proliferation of algae and/or cyanobacteria. Water may also be less available due to drought.

Wastewater networks will experience more “peaky” I&I which could lead to increased overflows in the network and at the plant and the inability to irrigate to land effectively.

The Horowhenua District has been identified as a high-risk area for earthquakes in New Zealand. The Kaikoura earthquake in 2016 caused significant damage to structures at the WWTP. When operators returned the following day visible leaks from the trickling filter structures were observed and had to be repaired. Subsequent smaller earthquakes have also caused damage according to operations staff.

2.6 HDC’S WIDER INFRASTRUCTURE CHALLENGES

The issues and risk for the WTP and WWTP sit within a wider context of infrastructure challenges that HDC face. As is typical of many jurisdictions, infrastructure needs and demands on budgets, expertise and staff time far exceed what is currently available, a situation that has developed over many years. For example:

- The wastewater network in Levin experiences very high levels of inflow and infiltration (I&I). During wet weather events flows can increase by a factor of five. It is known that inflow makes up a significant proportion of this. Significant I&I dictates that a steady programme of network renewals is also required. The renewals will have a positive effect on the WWTP by reducing the required hydraulic and treatment capacity however this effect will not be immediate and will gradually occur as renewals progress. Approximately \$2.5M has been set aside each year for renewals.
- Similarly, a programme of leak detection exists for the water networks.
- HDC are required to retrospectively apply for resource consent to discharge stormwater to Lake Horowhenua. The Lake is located close to the WWTP

and is significant to local iwi. Discharges of treated wastewater to the lake occurred until the 1980s. For these reasons protecting and restoring its wellbeing is a high priority. Improving the quality of stormwater discharges will be a key requirement in securing the resource consent. A major project that is already underway by the Horizons Regional Council is the construction of a wetland on the southeast side of the lake.

- HDC has made the decision to move to land application for the disposal of wastewater across the district, however the current volumes of rainfall in the region mean that this is already challenging. This issue is likely to become worse as rainfall volume and intensity increases over time due to climate change. HDC are currently working on an expansion of the footprint of the irrigation area at the "Pot".
- HDC have submitted a resource consent application for the construction of an offline water storage reservoir for Levin, fed from the Ōhau River. The storage would supplement the Levin water supply at times of poor river water quality and in drought.

Work and improvements at the WTP and the WWTP need to sit within this wider infrastructure context. Issues and risk at the plants need to be clearly defined and discussed, so that Council can understand the proposed projects and why they are assigned a recommended priority within the Three Waters strategy for the district.

This leads to the need for a robust and evidence-based masterplan – to properly assess the plant and present a risk assessment so that investments can be prioritized against others.

3. DEVELOPING THE MASTERPLAN

A masterplan is a comprehensive plan of action - in this case for the water and wastewater systems in Levin. Its purpose is to first assess the risks and need for action and then create a path to addressing the risks which includes definition of projects and funding requirements. The masterplans need to support district wide growth, legislative requirements, and environmental objectives as well as operational requirements.

The length of each masterplan is 30-years; however the plants will exist for a much longer period of time. Due to the long-term nature of the work, determination of immediate to medium-term needs is usually reliable however longer-term conditions and needs are harder to predict, as is technological development, and therefore the masterplans are designed to be flexible. Setting out the path of work will however put HDC on the right track to meet its obligations in the future.

HDC officers will use the plan to clarify needs and actions for presentation to Council. Council can then make informed decisions on the actions to be taken and prioritise these across competing demands in the district. Development of and reporting on the masterplans is part of the due diligence required by the WSA.

The general methodology that was used for undertaking the masterplan exercise is outlined below.

3.1 A BASIS FOR DESIGN

For both the WTP and WWTP masterplan a basis for design and understanding of HDC's needs and aspirations was documented. This enabled both the assessment of future capacity at the plants and the development of appropriate options for consideration.

For the WWTP available flow and load data was limited therefore:

- The predicted population in 2051 was provided by HDC and extrapolated linearly in the intervening years from the population in 2021.
- A typical domestic wastewater flow of 250 L/p/d was then assumed with the remainder of the dry weather flow assumed to be made up from tradewaste and infiltration.
- HDC network modelling projections were then used to estimate peak wet weather flows. A peaking factor of 3.9 was calculated.
- Typical domestic loads per capita were assumed with the remaining measured load attributed to tradewaste sources.
- Although the current discharge consents were not up for renewal until 2045 (24 years into masterplan) it was assumed that when they did pollutant limits would be much lower. For example: the loading rate limit for the Pot is currently 1440 kgN/ha/yr. In comparison Whangamata in Thames-Coromandel has a limit of 150 kgN/ha/yr once upgrades have been completed.

It was immediately recommended that additional data gathering (sampling and flow measurement) be undertaken to improve the accuracy of the capacity assessment.

For the WTP:

- The predicted demand in 2051 was provided by HDC. The predicted demand in the intervening years was then estimated by assuming a linear increase from the demand in 2021.
- The efficiency of the WTP was assumed to be 90%.
- Treated water targets and operating constraints were assumed to be as per Taumata Arowai's draft (at the time of writing) drinking water standards for New Zealand (Taumata Arowai, 2021), and draft drinking water quality assurance rules (Taumata Arowai, 2021).
 - In addition, it was assessed that cyanotoxin treatment would be required however treatment for nitrates or radiological determinants would not.
 - Treatment for viruses, which may be required in future, would be achieved using the two bacteriological barriers provided (UV and chlorine).

Qualitative objectives that were also considered in the development of options for both the water and wastewater plants included:

- Giving effect to Te mana o te wai;
- Demand reduction;
- Water recycling / reuse; and
- Resource and energy recovery.

3.2 CONDITION AND CAPACITY ASSESSMENT

The first step involved assessing the condition and capacity of the current plants.

A condition assessment involves evaluating major assets in terms of their age, design, construction methods and materials. Visual observations were initially made by Lutra staff and then a qualified structural engineer was brought in to provide an expert opinion, see Section 3.3.

The capacity assessment looked at the plant design and size of process units and determined theoretically if they were sized correctly for the current and future predicted demand and water quality (WTP) and flows load (WWTP).

The work was carried out by collecting the available information such as:

- As-built drawings;
- Operating and maintenance manuals;
- Details of design work from previous upgrades;
- Flow and load data for the WWTP;
- Demand data for the WTP;
- Resource consents; and
- Plant performance data (SCADA and/or laboratory test results).

The records provided are typically imperfect. Not all drawings are available, and details of design work are often missing. Laboratory tests may not cover all the parameters of interest over a sufficient period and overflows are difficult to measure accurately. To address this, we had to make a number of educated assumptions, measure physical dimensions on site or from aerial photos and arrange to collect more data. Additional data collection included installation of flow measurement devices and a sampling programme for the WWTP.

Site visits were also conducted together with the site operations staff. The site visits were essential to understanding the risks and operational issues faced at each plant. Being at the plant every day and having to use and manage the plant and equipment gives the operators detailed knowledge of its faults and foibles. Operators also have had time to think about potential solutions and how this would work on their site.

The site visits highlighted immediate health and safety issues such as the condition of the sludge storage tank at the WWTP. In this case remediation work had already been planned and has since been completed.



Figure 5: Deterioration of Sludge Storage Tank Roof

The following are key findings in this assessment for the WWTP and WTP.

WASTEWATER TREATMENT PLANT

- Much of the WWTP is in **poor structural condition**. Cracks can be seen in the concrete structures which are due to both age and seismic events. This includes the structures containing the main biological processes i.e. the trickling filters and digesters.



Figure 1: Tricking filter showing structural condition

- The WWTP is **hydraulically limited** at the inlet works, outlet of the trickling filters, effluent pumpstation and effluent disposal scheme (the pot).
- Operations staff spend a high proportion of their time **managing problems** with the equipment operation. For example, grit transferred through the system causes excessive wear and tear on dewatering equipment; the rotary presses are temperamental and sludge storage is undersized.
- The WWTP is also reaching its **process capacity limits** to remove waste organic matter (BOD) and nitrogen. Nitrogen removal is not expected past 2026. We note that of the issues identified, this is the only one that could potentially change with collection of better load data.

WATER TREATMENT PLANT

- The **hydraulic capacity** of the WTP is limited at the clarifier, filters, UV and chemical dosing and storage. Demand is expected to exceed capacity in 2026. The treated water reservoir also has less than 24 hours storage
- Demand is close to the **abstraction consent limit** during current peak periods and will likely exceed the limit at average conditions by 2026.
- This is compounded by variations in the natural position of the river above the intake gallery and buildup of silt and debris which limit the volume of water that can be taken.
- **The pressure filters are in moderate to poor condition** with one filter having to be taken offline permanently and another prone to breakthrough during raw water events.



Figure 2: Pressure filters at Levin WTP

- The **waste system** is also reaching capacity and **consent breaches are expected** within 5 years.

3.3 IDENTIFICATION OF FURTHER INVESTIGATION WORK AND IMMEDIATE NEEDS

From the capacity and condition assessment it became clear that further investigation work was required to confirm the findings, define timelines, and provide information for the next steps.

Further investigations that were recommended included:

- Structural and seismic assessments on buildings and major structures to confirm percentage of new build standard (%NBS) and remaining life.
- Inspection to determine the internal condition of filters (WTP).
- Detailed condition assessment of the inlet works (WTP).
- Electrical studies to confirm condition and capacity of the electrical supply to the WWTP and WTP and each supply network.
- Additional source water monitoring (WTP).
- Wastewater influent study (flow and load).
- Geotechnical investigations on available land.

Several areas of the WWTP were identified for immediate attention including addressing the impact of grit carryover from the inlet headworks, undertaking repairs to address health and safety risks due to the condition of the sludge storage tank and continuation of plans to extend the area of irrigation available at the Pot.

At the WTP it was recommended that abstraction consent limits and capacity issues at the infiltration gallery, clarifier, filters, treated water storage, and waste plant also be addressed immediately.

3.4 DEVELOPMENT OF THE DRAFT MASTERPLAN

3.4.1 Addressing Risk

Options to address each of the risks and needs identified in the condition and capacity assessment were then developed. Some of the risks could be addressed using many different process technologies, however at this level of planning many sensible options for individual process components are similar in terms of process outcome, footprint and expenditure. A placeholder choice was made in conjunction with HDC, identified as such, and will be used as a baseline for options assessment in the future. Operational impacts and preferences were taken into account in selection of placeholder options.

3.4.2 Investment Pathways

The projects were then grouped into two or three potential investment pathways for analysis and presentation to HDC. The pathways lie on a scale of effort and commitment with two extreme ends. The pathways were selected to enable understanding of the risks and benefits of each.

The expert technical knowledge gathered in the previous work allowed the timeline of projects to be set.

The pathways are described below.

Scenario 1: Do Minimum

Scenario 1 was based on minimal capital investment to spread out expenditure for as long as possible across the 30 years through running-to-failure, refurbishment, and reactive replacement of plant equipment.

This option would allow the WTP to meet its compliance requirements under Taumata Arowai's rules, however for both the WTP and WWTP it exposed HDC to consent breaches and health and safety risks. At the WWTP, it poses unacceptable risk of structural failure.

Refurbishing ageing equipment would ultimately result in diminishing returns as repairs become increasingly expensive and less effective over time until replacement is required. Ultimately the capacity of the existing WTP or WWTP would not be sufficient, and renewals will be required anyway. This sort of 'delaying' tactic is common when budgets are constrained or the risks posed by asset failure are not well articulated or understood. It is well documented that Aotearoa New Zealand faces a wave of investment requirements as the end of life of many infrastructure assets approaches.

Scenario 1 was not recommended.

Scenario 2: Proactive Renewal and Upgrade

Scenario 2 was based on a prioritised approach to upgrading the plants. This included best practise options to meet the drinking water standards requirements and minimise the risk of consent breaches.

Failing structures would be replaced, and replacement processes would be scalable where possible, so that additional trains and units could be added to meet demand over time.

For the WWTP this also meant the selected projects would “future proof” the plant for provision for phosphorous removal, potable water re-use, Combined Heat and Power and other resource recovery as required in the future.

Upgrades under scenario 2 could be delivered in two ways. As one large plant upgrade which addresses the immediate needs, followed by smaller upgrades to address growth. Or project-by-project upgrades as the programme dictates or funding allows. These sub options have been analysed in more detail for the WWTP in Section 4.

Scenario 2 was the recommended option.

One further scenario was presented for the wastewater plant as follows.

Scenario 3: Resource Recovery Facility

Scenario 3 consisted of all the projects identified in Scenario 2 with the addition of advanced processes for nutrient reduction and external water reuse and CHP and THP plant to aid resource recovery and reduce operating costs.

Scenario 3 was not considered feasible at this stage given the very high expenditure needs of the WWTP simply to renew and upgrade the existing assets, and the significant planning and consultation required to implement an external water reuse plant. However as noted, plant renewals and upgrades under Scenario 2 can be designed so that integration with future resource recovery systems is possible.

3.4.3 Adding the Detail

For each pathway, development of the projects involved carrying out initial sizing calculations, high level capital costs estimates (+/-50%) and preliminary layouts.

The projects were prioritised by risk and the estimate of when they would be required i.e. when the existing plant reached capacity and/or consent breaches were likely or at the end of the estimated remaining life. The projects were then arranged on an investment timeline.

The final step was to present the pathways along with timelines, advantages / disadvantages and high-level costs at workshops conducted with HDC and Lutra.

4. THE MASTERPLANS

4.1 LEVIN WWTP

Proactive renewal and upgrade is the recommended option for the Levin WWTP. As noted before this could be delivered either as a significant initial upgrade to address risk with smaller growth upgrades over time (2a) or project by project as funding allows (2b).

Both scenarios address all of the identified risks and legislative obligations although it will take longer for 2b to achieve this.

The estimated total cost of work for Scenario 2a is \$64 million ($\pm 50\%$).

This consists of an initial upgrade to the plant which addresses the immediate risks (investigations, previously planned works and upgrades to inlet works, biological treatment, thickening and digestion processes and sludge dewatering) totalling \$34 million ($\pm 50\%$). Design would commence as soon as possible with physical works scheduled to begin in the 23/24 financial year and completed within 5 years

The remaining work would be subject to the realisation of growth starting with an expansion of the biological treatment process (\$4 million ($\pm 50\%$)) estimated to be required in the 30/31 financial year. Additional work would include expansion of the inlet works, construction of a new primary clarifier, further expansion of the biological treatment plant, digestion and dewatering. These are all spread over the remaining 20-years of the masterplan.

The estimated total cost of work over 30-years for Scenario 2b is \$69 million ($\pm 50\%$).

The scope of the immediate work identified in 2a (investigations, previously planned works and upgrades to inlet works, biological treatment, thickening and digestion processes and sludge dewatering) would be spread over the first 10 years (to financial year 30/31) or as funding allows at an estimated cost of \$38 million ($\pm 50\%$). This approximately \$4 million more over the 10-year period compared to 2a.

Option 2a was recommended for the following reasons:

- Overall costs could be reduced because cost efficiencies during the design, site establishment and project management could be realized, and inflation risk is reduced by securing contracts as early as possible.
- A new greenfields plant would be built on the site adjacent to the existing plant (on land already owned by HDC and designated for wastewater treatment) minimising break-ins, temporary/transportable upgrades and disruption to the existing site.
- HDC would be more likely to obtain competitive bids and will have more choice in preferred provider as large value contracts will likely be appealing for contractors and/or consultants to tender.
- One lead contractor on-site would have responsibility for controlling any sub-contractors and health and safety.
- Plant design will be holistic as it will cover the entire liquid and solids treatment process.
- Having one lead contractor will also make assessing performance and remediating issues less complex.

However, this approach would rely on HDC being able to secure additional funding above what is allowed for currently in the LTP. The total cost of upgrade is also required much sooner than if projects are spread over time.

In addition, operations may also have to wait longer for relief with respect to operational issues and some spend to address current operational problems is still likely to be required.

For either method of delivery HDC would need to secure an experienced project and contract manager (and potentially assistant manager/s) to deliver the upgrades.

4.2 LEVIN WTP

The final masterplan for Levin WTP was also based on proactive renewal and upgrade (Scenario 2) however due to the restrictions in water availability there are unknowns with respect to the water source beyond year 10. This provides a driver to reduce demand and to make the WTP as efficient as possible.

A major focus of the first five years was therefore to investigate and secure a long-term water source (or sources) for the community and to concentrate on demand management, efficiency and reduction.

As noted previously HDC has applied for a resource consent to construct offline raw water storage utilising the existing source. For cost estimation with respect to treatment it was assumed that source quality would not change over the longer term.

Installing a waste system would reduce demand by one million litres per day (MLD), reduce impacts on the river from abstraction and discharge and therefore help meet Te Mana o Te Wai. This was therefore also recommended in the first 5-years.

For budgeting purposes an allowance was made for upgrades between year 10 and 30 however without knowing the changes to the source, or availability of additional sources it was advised to use any predictions beyond year 10 with caution.

The estimated total cost of work in the first 10-years is \$40 million -57 million ($\pm 50\%$). This consists of:

- Additional data gathering (investigations, network modelling, and structural assessments).
- Selection and testing of wells (new source if required).
- New reservoirs 40 ML.
- Second clarifier, flocculation tanks and equipment.
- An upgrade to the waste treatment system.
- Rapid gravity filters.
- A second taste and odour (T&O) UV unit.

Note that investigation and provision of a new water source (storage reservoir) had already been allowed for in the LTP with \$18 million to be invested over 10-years.

Beyond year 10 an additional \$15 million was recommended for budgeting purposes based on extending the existing plant to treat the same source water. This figure requires review once alternative sources have been confirmed.

5. CHALLENGES AND NEXT STEPS

Both the water and wastewater treatment plant masterplans have now been finalised. The structural and capacity assessment at the WWTP has confirmed that a new biological treatment process is required within 5-years. The assessment at the WTP has also shown that capacity risks need to be addressed within 5-years through a combination of additional source capacity and increased efficiency.

There is however significant additional work required before physical changes will be seen at site. The following sections outline the next steps for HDC and the challenges they are facing.

5.1 STUDIES, PRELIMINARY DESIGN AND TENDERING

HDC now require a range of studies, preliminary design and tendering to be carried out in preparation for the selection, detailed design and construction of upgrades. This will likely be outsourced to a variety of consultants with HDC wishing to select the most appropriate and experienced for each type of work.

For the WWTP the priority is to complete the influent study which includes sampling and flow monitoring. Flow monitoring is especially important to understand peak flows to the plant including the volume that currently overflows to the ponds or ground. The sampling study will enable a better understanding and prediction of loads.

The completion of the influent study would then allow for an options study and selection for biological treatment process and dewatering system, feasibility study for a thermal hydrolysis and combined heat and power plant (THP/CHP), and completion of hydraulic modelling to confirm future flows and buffering capacities. All of these need to be completed with urgency to enable design work to begin and to meet the 5-year timeline for the replacement of the trickling filters.

Similarly, the WTP is under a 5-year timeline to avoid consent breaches and therefore the priority is to complete an options assessment for a new WTP waste system followed by design and tendering, and to complete the consent process for the new source (offline storage reservoir).

To assist in the management of the reservoir and source the following work would also then be required:

- Assessment of the cyanotoxin risk from the source water, considering the proposed reservoir, and creation of a management plan to correctly scope the taste and odour treatment.
- Assessment of the impact of the proposed reservoir on the source water quantity, and quality and whether additional treatment will be needed.
- Review of existing demand management programme and scope necessary studies and remediation.

The WTP masterplan also requires updating with respect to the long-term treatment budgets when the reservoir is confirmed.

After this the priority will be to complete the following to meet the 5-year timeline identified in the masterplan:

- Design and tendering of modular filters and clarifier.
- Develop network model and examine storage locations; begin discussions with developers over location if appropriate.

The completion of structural assessments of the filters may also change the urgency of this work.

5.2 PRESENTATION TO COUNCIL

Key to gaining support and commitment to the masterplan (including a commitment of financial resources) from the chief executive, councilors and other stakeholders is making the risks and options very clear.

Presentation of the entire masterplan document would be too complicated and time consuming for most stakeholders. For this reason, a council paper has been prepared for the WWTP which very clearly sets out the purpose i.e. to outline management options and to request a decision from council, the major risks, HDC's obligations under current legislation and a discussion and recommendation of options.

This information will also be presented in person to council by the Water and Waste Services Manager. This will enable further discussion and clarification of questions from the Councilors.

To support the understanding of risk it is also planned to conduct site visits as being confronted with the reality of each plant will have more impact than words or even photographs.

5.3 CONSULTATION

As noted previously, critical to the decision making regarding a water or wastewater system is involvement with iwi. A platform for engagement of iwi is already established via the resource consent for The Pot. A plan for engagement of iwi, presentation of the current situation and risks and gaining input with respect to their values and objectives will be developed and implemented. A comprehensive plan for engagement of other stakeholders including the wider community in Levin will also be developed.

6. DISCUSSION

The WTP and WWTP are not in the best shape, as determined in the condition and capacity assessments. Age and years of underinvestment is catching up particularly at the WWTP and this presents the need for a very large investment. The requirement for funding also sits within the context of the investment required in the reticulation network, for stormwater and for the other water and wastewater schemes in the district. The budget set out in the LTP for Levin over the next 10 years is minimal in comparison to what is required within 5 years.

There is an urgent need to understand and manage risk. The new legislation (WSA) and regulator (Taumata Arowai) makes individuals personally liable; this means service managers can be upfront and explicit about problems with the backing of the legislation. In the current state however budget holders are not individually liable therefore action is still subject to their decisions. Due diligence on the part of Council Officers will involve identifying and highlighting risk to Council.

The masterplan process enabled the clarification of risk and provided a comprehensive plan to manage the risks identified. Theoretical analysis, expert opinion and detailed operational knowledge were combined to develop the plan. The plan is high level with decisions on individual process technology to be made once more information is known. A masterplan also needs to be achievable. Consideration of available space, timelines and delivery methods were also included.

There is now a need to present clear and factual information to Councilors to request a decision on the path forward. These individuals may not have a full understanding of the current condition of assets and therefore the extent of investment required may be surprising. They may also not fully understand the potential liabilities of not addressing the risks. Political pressures relating to the proposed creation of new water entities is also another factor to consider.

Ideally the masterplan budgets would be included in the asset management plan (AMP). Having the masterplan and funding in the AMP would in our opinion put HDC in the best position to carry on with their plans if the proposed water entities go ahead.

Once a decision has been made to go ahead HDC needs to consider how to execute the plan. There will be a need to attract and retain good, experienced people in the three waters space. This has been a challenge in the past and HDC are not currently in a position to deliver large work programmes. Required roles for large projects such as this include contract and project managers, construction supervisors and health and safety officers. HDC will also require suitably experienced people for input into the design and operability of a new plant. It is unpalatable to contract all this work out. In addition, there will also be a challenge to secure suitably experienced design engineers and/or contractors within the required timeframes given the workload facing the three waters industry in New Zealand in the near future.

It is fair to say developing a masterplan for a plant is the easy part. Gaining commitment and then delivering the work will be a much bigger challenge.

7. CONCLUSIONS AND RECOMENDATIONS

The masterplans for the WTP and WWTP are now complete. A high-level concept design of new plants is just one part of the planning puzzle. The master plan also needs to highlight risks not just to the plant but in delivery of the new plant. Masterplanning forms a major part of the due diligence now required by the Water Services Act.

Urgent studies, preliminary design and tendering identified in the masterplan has been prioritized to enable HDC to be able to build and commission solutions to address the immediate risks within 5-years. This work can carry on regardless of any higher-level decision making regarding the acceptance of the masterplan or noise related to the transition to entities.

The risks and proposed solutions need to be presented to council for decision making. Consultation also needs to begin. Masterplan budgets should be included in the AMP to position HDC for a proposed change to Entity C.

Finally, the question of how to put skilled and experienced people in place to deliver the masterplan also needs to be addressed and appropriate action taken. This is both within council and within the expert team chosen to design and construct the projects.

Clearly there are many steps involved in getting to a place where physical assets are being built on site. Water Services managers need to be proactive but just take each step one at a time.

ACKNOWLEDGEMENTS

Barrie Wallington (3-waters Asset Engineer, HDC), Elysia Butler (Water and Wastewater Treatment Supervisor, Downer), Peter Giddens (Process Operator, Downer), Adrian Parkes (Process Operator, Downer), Andrew Thompson (Structural Engineer, Envelope), Amanda Slater (Process Engineer, Lutra), Ciaran Hyland (Process Engineer, Lutra).

REFERENCES

Environment Waikato. *Resource Consent Number 114795 to Discharge treated Wastewater to the Tairua Forest in association with the operation of the Whangamata Wastewater system.*

Horizons Regional Council. *Resource Consent Number ATH-201820041.00 to store wastewater and the associated discharge of wastewater to land and water & ATH1998004064.01 to discharge treated wastewater to land and water.*

Horowhenua District Council 2021, *Horowhenua District Council Website*, accessed 13 August 2022, < <https://www.horowhenua.govt.nz/Growth-Projects/Climate-change-for-our-district-and-region> >

Taumata Arowai. (2021). *DRAFT Drinking Water Quality Assurance Rules.*

Taumata Arowai. (2021). *DRAFT Drinking-Water Standards for New Zealand 202X The Standards Standards and Aesthetic Values.*

Water Services Act 2021.

<https://www.legislation.govt.nz/act/public/2021/0036/latest/LMS374564.html>