

Sand Removal: Past Industry Operation in Present Water Treatment Process



Presenter: Rebecca Upton-Birdsall (Watercare Services Limited)
Co-authors: Axel Dumont (Watercare Services Limited) and Rob Burchell (Beca)

Historical Tuakau Sand Limited Operation



Historical Tuakau Sand Limited Operation



Historical Tuakau Sand Limited Operation



Historical Puni Sand Dredging Operation



Waikato Water Treatment Plant



Waikato Water Treatment Plant



Waikato Water Treatment Plant



Issues: Pump Wear



Issues:

Raw Water Wet Well Sand Accumulation

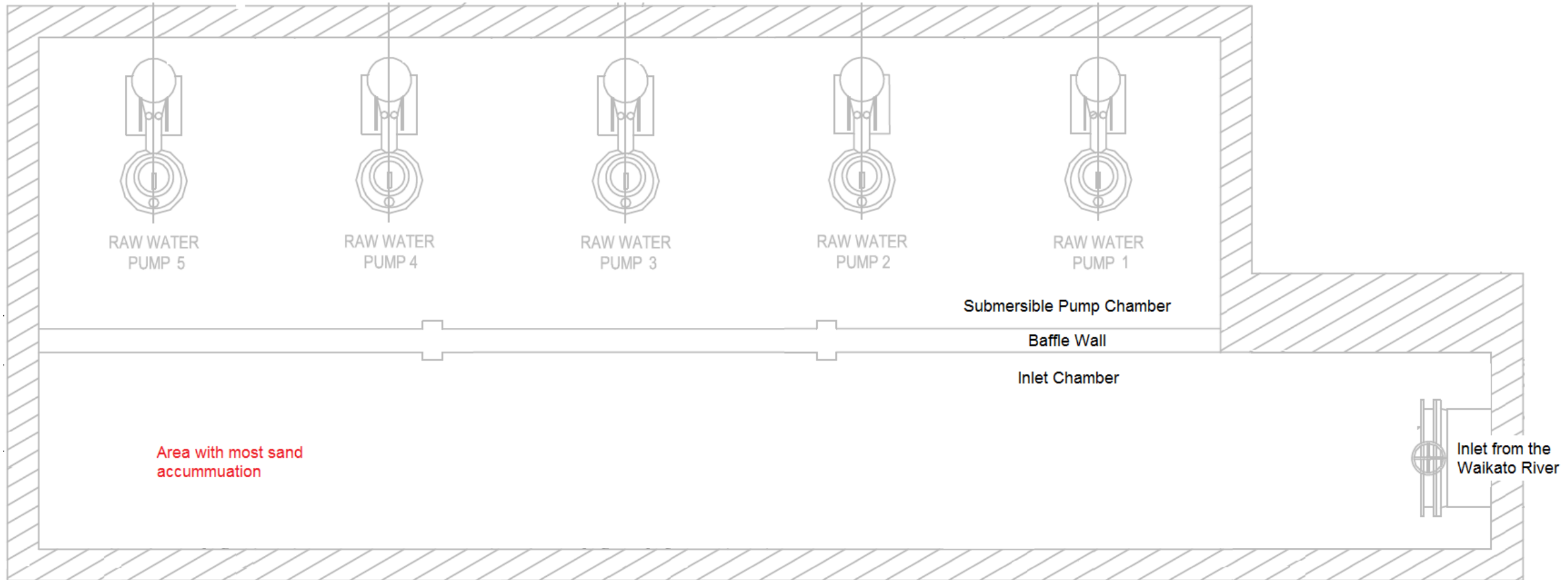

Issues: Clarifier Sand Accumulation

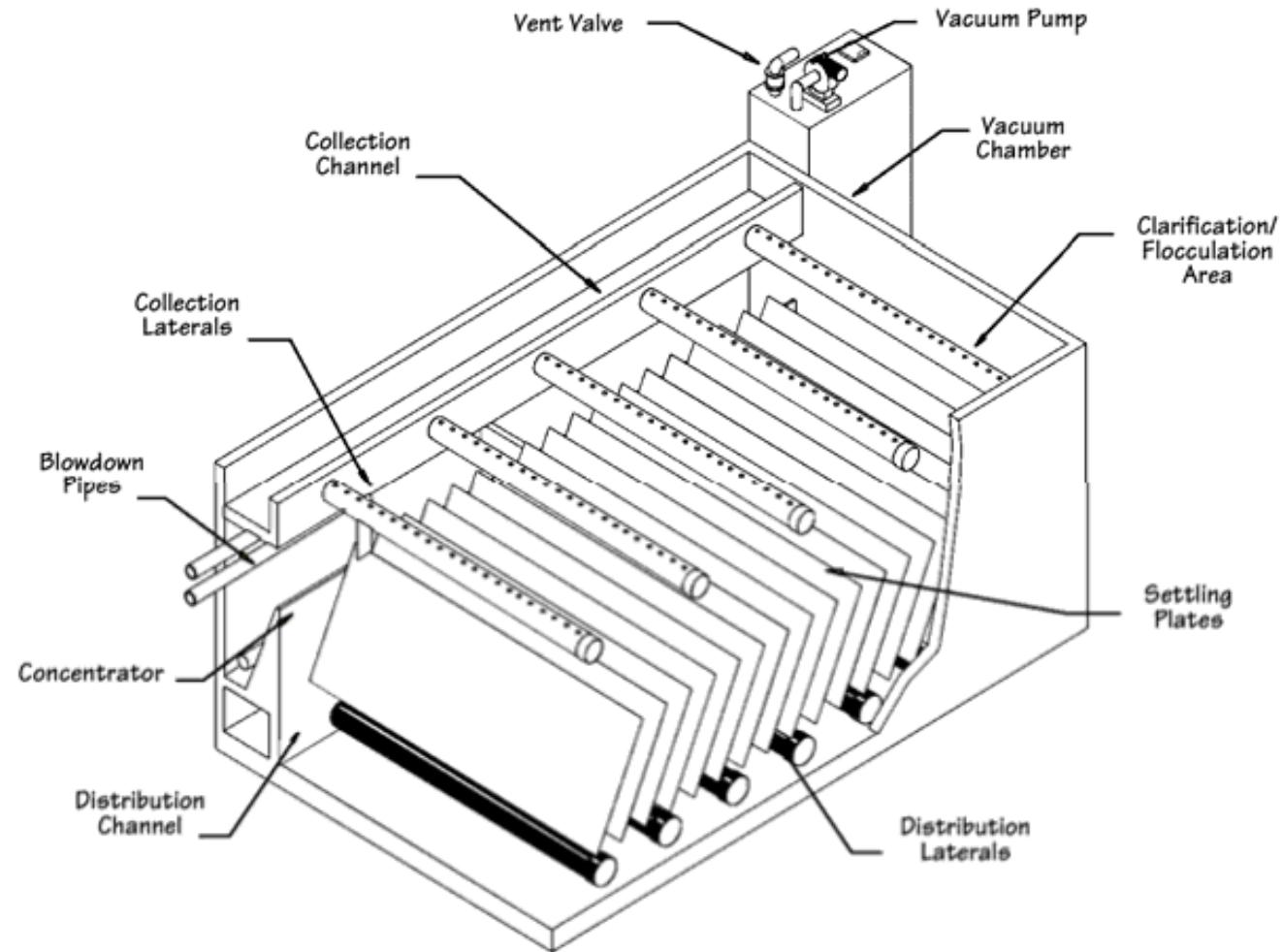

Issues: Clarifier Sand Accumulation



Issues: Clarifier Sand Accumulation



Sand Separation System Upgrade



Sand Separation System Upgrade



Sand Separation System Theory and Control

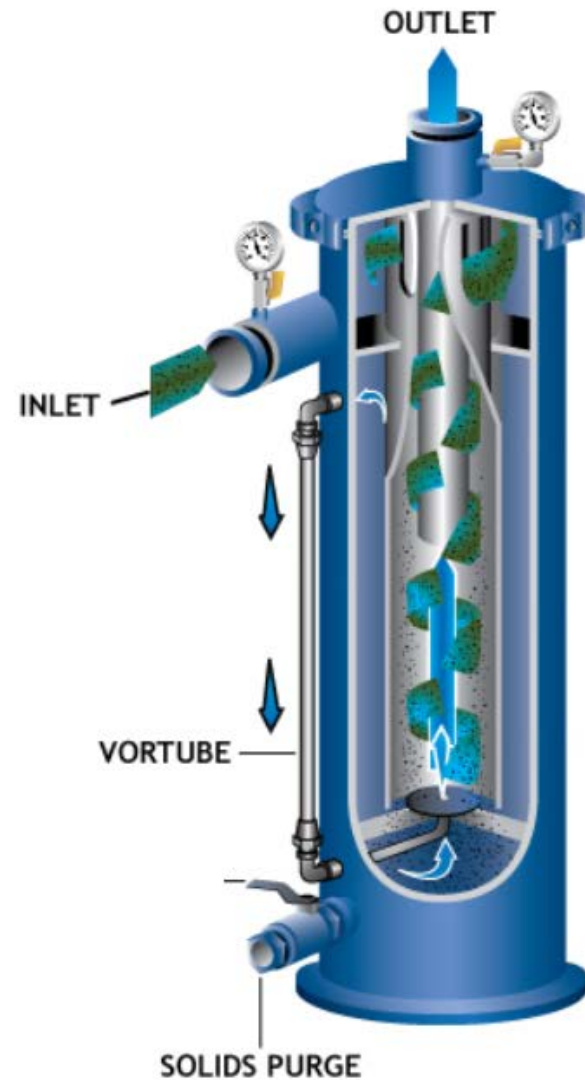

Sand Separation System Commissioning and Operation: Sand Accumulation



Sand Separation System Commissioning and Operation: Sand Accumulation



Sand Separation System Commissioning and Operation: Headloss and Raw Water Pump Performance

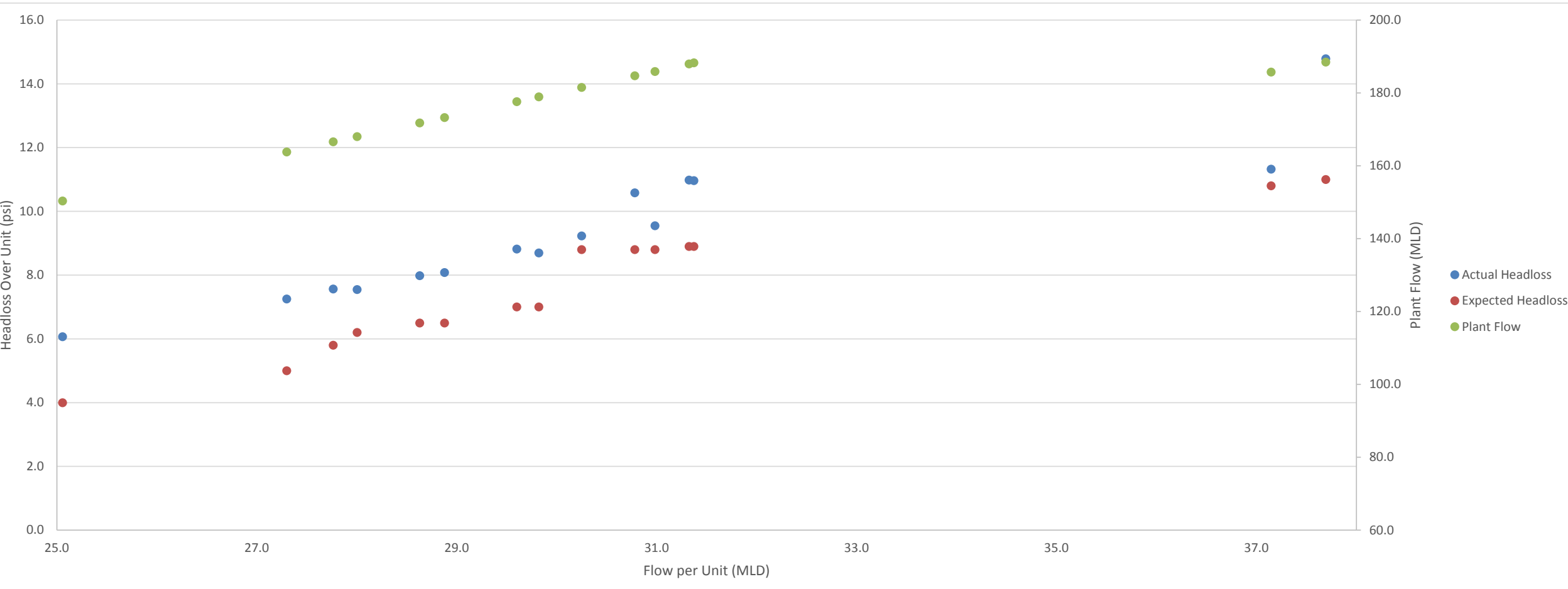

Sand Separation System Commissioning and Operation: Vibration



Sand Mobilisation Upgrade



Sand Mobilisation Upgrade



Sand Mobilisation Upgrade

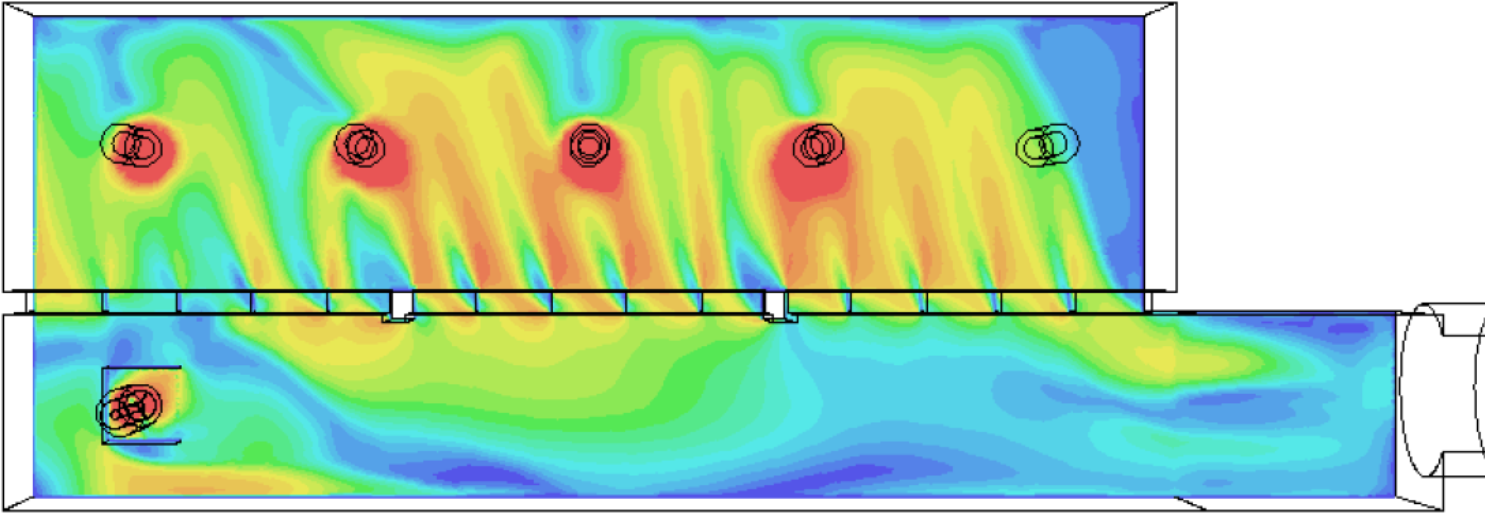
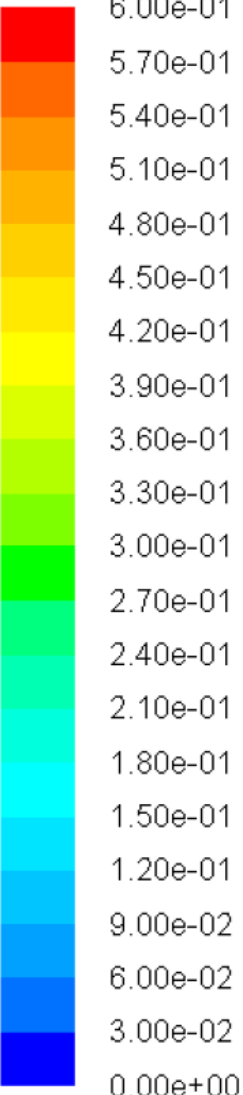

Results



Conclusions

- Sand separation system successfully removing sand
- Sand is mobilised in the raw water wet well
- Process performance improved
- Maintenance costs reduced
- Removed sand has been repurposed within the business